

Switching Power Supply Type SP D 24-60 DIN Rail mounting



- Universal AC Input Full range
- Installation on DIN Rail 7.5 or 15mm
- Short circuit protection
- Overload protection
- High efficiency
- LED indicator for power on
- Power Ok output
- CE, TUV approved and cULus Listed

Product Description

The Switching power supplies SPD series are specially designed to be used in all automation application where the

Installation is on a DIN rail and compact dimensions and performance are a must.

Approvals



Ordering Key

SP D 24 60 1 B

Model _____
 Mounting (D = Din rail) _____
 Output voltage _____
 Output power _____
 Input Type _____
 Optional features _____

Input type : 1= single phase

Optional Features

Description	Code
Spring connectors	B

Output data

Output nominal voltage	24Vdc*	Transient recovery time	300µs
Current	2.5A	Ripple and noise	50mVpp
Output voltage range	24 to 28Vdc	Efficiency typ.	84%
Line regulation	± 1%	Output Voltage accuracy	± 2%
Load regulation	± 2%	Temperature coefficient	± 0.02%/°C
		Hold up Time Vi = 115Vac	20ms
		Hold up time Vi = 230Vac	75ms

Input data

Rated input voltage	100 - 240	Frequency range	47 – 63Hz
Voltage range		Inrush current	
AC	85 – 264Vac	Vi = 115Vac	21A
DC	120 – 370Vdc	Vi = 230Vac	42A

* 5Vdc, 12Vdc and 48Vdc available upon request

Specifications are subject to change without notice



Controls and Protections

Overload	105 – 125%	Output Short Circuit	Hiccup mode
Input Fuse	T2A/250Vac internal*	Power ready	20 – 24Vdc

*not replaceable by user

General data (@ nominal line, full load, 25°C)

Ambient temperature	-10°C to 71°C	Cooling	Free air convection
Case temperature V/I nom	+85°C	Switching frequency	50kHz
Derating (>60°C to +71°C)	2.5%/°C	MTBF (MIL-HDBK-217F)	167.000h
Ambient humidity	<90%RH	Case material	Plastic
Storage	-25°C to 85°C	Dimensions L x W x D	90 x 40.5 x 115
		Weight	360g

Approvals and EMC

Insulation voltage I / O	3.000Vac	CE	EN55022 Class B EN55024 EN61000-3-2 EN61000-3-3
Insulation resistance	100Mohm		
UL / cUL	UL508 listed, UL1950, UL1310 Class 2 Recognised		
TUV	EN60950		

Block diagram

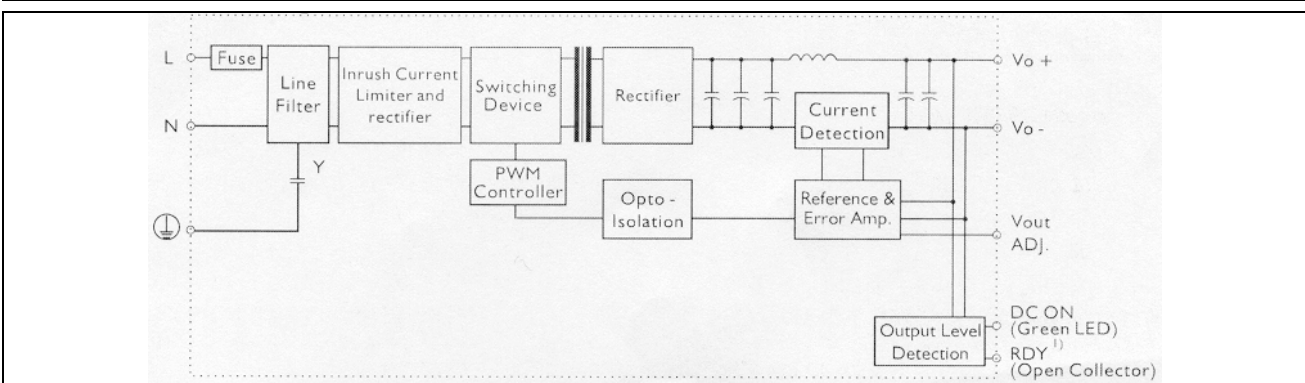

Pin assignment and front controls

Pin No.	Designation	Description
1	RDY	DC OK, output for relay (only on 24Vdc models)
2	+	Positive output terminal
3	+	Positive output terminal
4	-	Negative output terminal
5	-	Negative output terminal
6	GND	Ground terminal to minimise High frequency emissions
7	N	Neutral input (no polarity with DC input)
8	L	Phase input (no polarity with DC input)
	Vout ADJ	Trimmer for fine output voltage adjustment
	DC ON	DC output ready LED

Output Rdy Wiring diagram

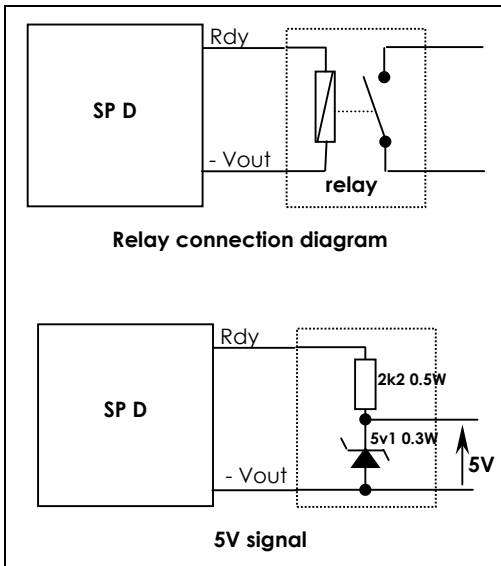

Derating Diagram

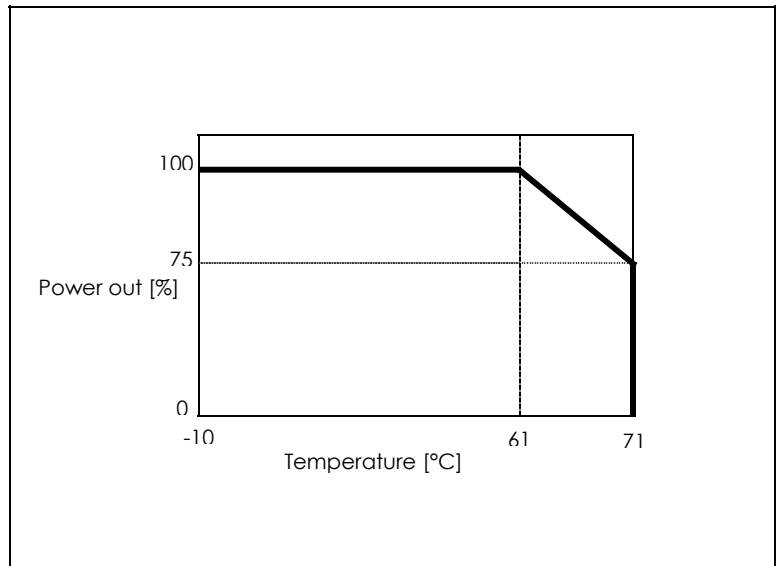

Mechanical Drawings

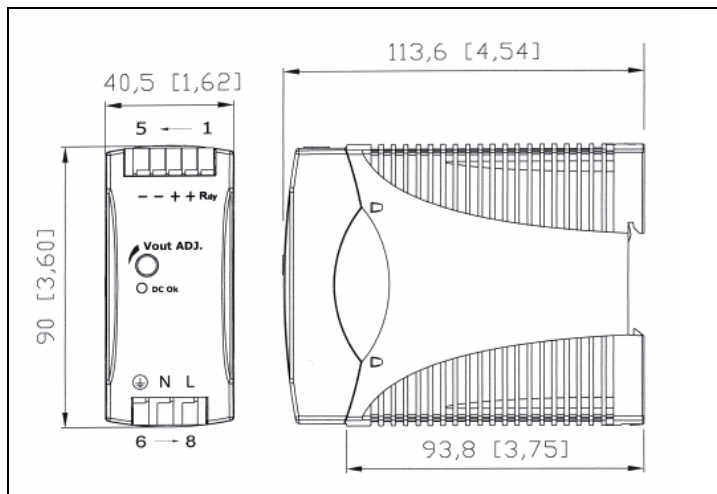

Installation

Ventilation and cooling	Normal convection All sides 25mm free space for cooling is recommended
Connector size range	Solid: 0.2 – 2mm ² (AWG24-14) (use copper conductors only)